

 **Operating and  
Safety Instructions**

 **Gebrauchs- und  
Sicherheitsanweisung**

 **Bedienings- En Veiligheidsin-  
structies**

 **Istruzioni Per L'uso E La  
Sicurezza**

 **Instructions D'utilisation &  
Consignes De Sécurité**

 **Instrucciones De Funcionamiento  
Y Seguridad**



Thank you for purchasing this Triton tool. Please read this manual: it contains information necessary for safe and effective use of this tool, and will enable you to get the full benefit of the tool's unique design. Keep this manual close at hand and ensure all users of this tool have read and fully understand the instructions.

## CONTENTS

Symbols	2
Warranty	2
Parts List	3
Assembly	3

## SYMBOLS



Always wear ear, eye and respiratory protection.



Instruction warning.



Do not use before viewing and fully understanding the operating instructions

## WARRANTY

To register your guarantee visit our web site at [www.tritontools.com](http://www.tritontools.com)\* and enter your details.

Your details will be included on our mailing list (unless indicated otherwise) for information on future releases. Details provided will not be made available to any third party.

Triton Precision Power Tools guarantees to the purchaser of this product that if any part proves to be defective due to faulty materials or workmanship within 12 MONTHS from the date of original purchase, Triton will repair, or at its discretion replace, the faulty part free of charge.

This guarantee does not apply to commercial use nor does it extend to normal wear and tear or damage as a result of accident, abuse or misuse.

\* Register online within 30 days.

Terms & conditions apply.

This does not affect your statutory rights

## PURCHASE RECORD

Date of Purchase: \_\_\_ / \_\_\_ / \_\_\_

Model: SJA470

Retain your receipt as proof of purchase

## PARTS LIST

1. Front Jaw (1)
2. Rear Jaw (1)
3. Coach Bolts (4)
4. Mounting Knobs (4)

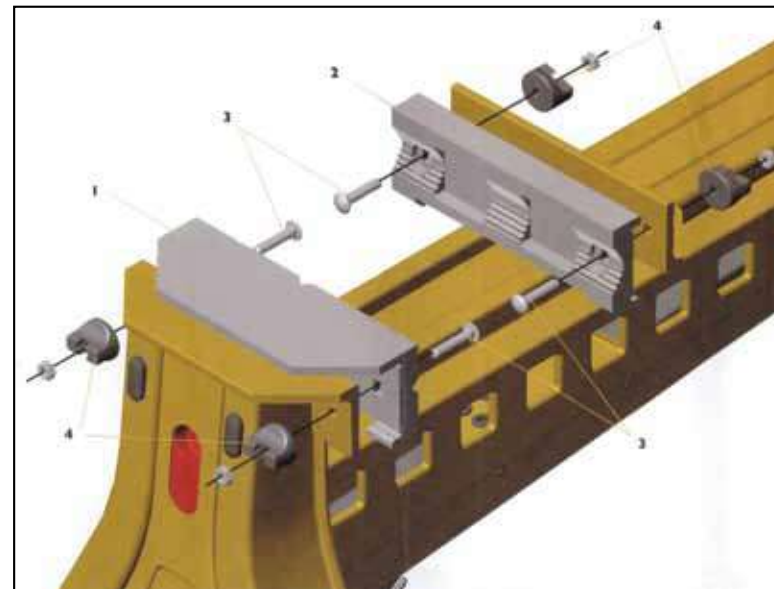

## ASSEMBLY

### REMOVING THE URETHANE JAW FACINGS

#### Step 1

Remove the fixed jaw facing: use a screwdriver or similar to pry the facing off the fixed jaw.

#### Step 2

Remove the moving jaw facing: Push the backing face to the right (when viewed from the front of the Superjaws) to disengage the connection pins. You can then remove first the backing face and then the front face.

### FITTING THE ENGINEERS JAWS

See Diagram, page 3

#### Step 1

Position the Front Jaw (1) onto the fixed jaw so that the flanged edge is located on top of the fixed jaw.

#### Step 2

Thread the Coach Bolts (3) through the aligned fixing holes in the Engineers Jaws and the fixed jaw, so that the bolt heads locate in the fixing positions in the front of the Engineers jaws.

#### Step 3

Fit the Mounting Knobs (4) onto the bolts and tighten to secure the Front Jaw (1) in position.

#### Step 4

Position the Rear Jaw (2) onto the moving jaw so that the flanges locate over the top and bottom of the moving jaw

#### Step 5

Secure the Rear Jaw (2) using the remaining Coach Bolts (3) and Mounting Knobs (4)